

**maxtruder**

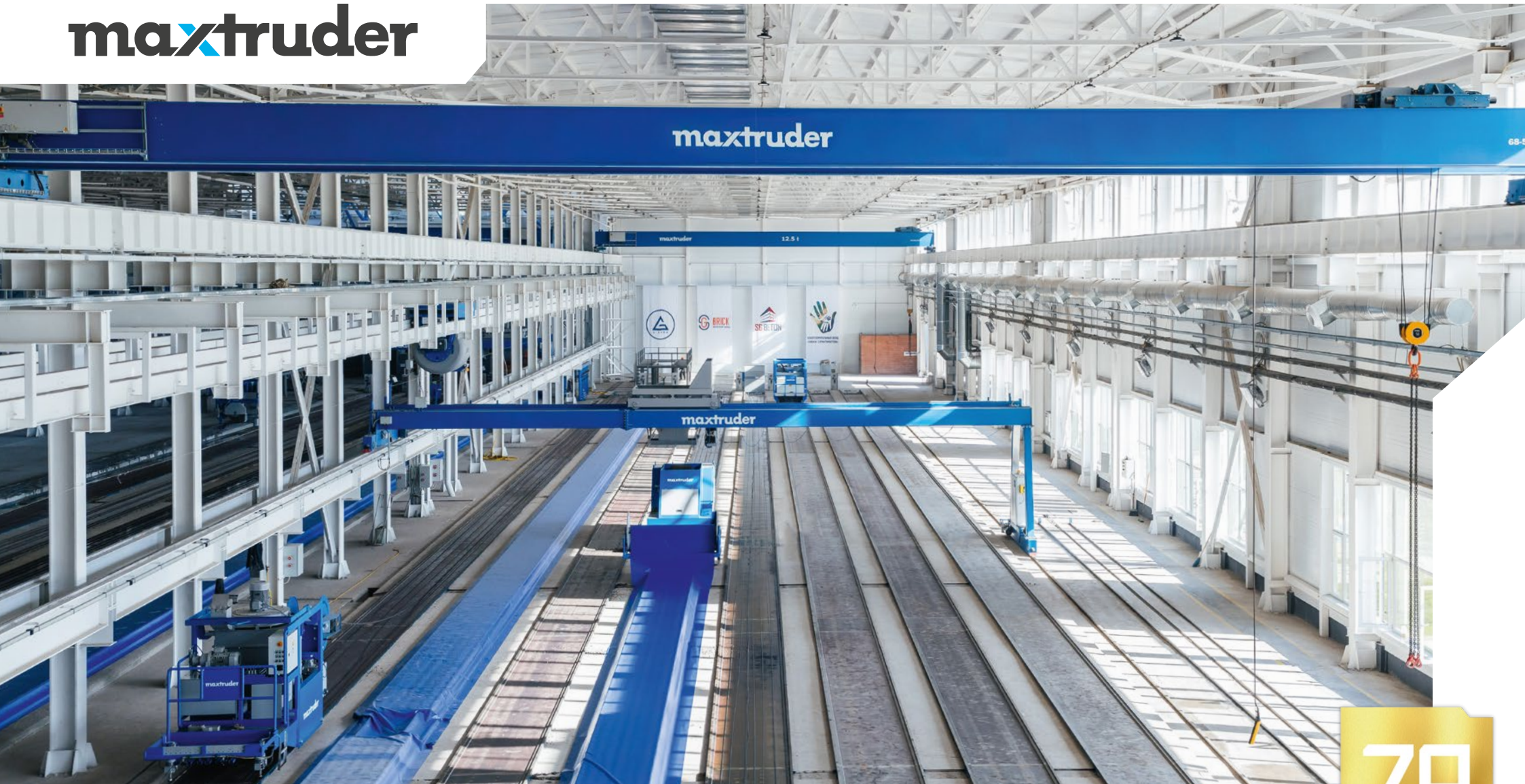

**maxtruder**

**maxtruder**



**YOUR RELIABLE PARTNER  
FOR PRECAST CONCRETE FACTORIES.**



Head office MAX-truder GmbH - Sudenburger Wuhne 60, 39116 Magdeburg, Germany  
Branch office MAX-truder GmbH - Rheinstraße 40, 55435 Gau-Algesheim, Germany

---

*Explore your precast future.*



## ABOUT MAX-TRUDER

In 2024, MAX-truder GmbH proudly celebrated 70 years of experience, expertise and tradition in the precast concrete industry, highlighting a remarkable journey of success. Since 1954, we have successfully installed over 450 precast concrete factories worldwide, establishing ourselves as a global leader in tailor-made solutions for the efficient production of precast concrete elements. Our name stands for the highest quality and reliability – values that our customers depend on every day.

Through our extensive international network, we serve major markets around the world, offering advanced technology and innovative solutions. Our modular MAX-truder machines and factories provide unparalleled flexibility, allowing our customers to easily adapt to changing market demands.

At the heart of our success is our commitment to pioneering precast construction technology. From scalable factories to machines that produce the strongest hollowcore slabs with the fastest curing times and lowest cement consumption, MAX-truder leads the way in industry advancements. Our error-proof prestressing and post-tensioning equipment, along with revolutionary concrete cutting technology, are all developed, designed and manufactured in Germany, ensuring the highest standards of quality, precision and durability.

As we continue to innovate and grow, MAX-truder remains committed to shaping the future of the precast concrete industry, setting new global benchmarks for quality and efficiency.



CEO – Stefan Wittek

---

*„With over 70 years of experience, MAX-truder is a reliable partner known for its expertise and cutting-edge technologies in the precast concrete industry. Our team is committed to deliver high-quality products according to the customers' requirements.“*



COO – Arne Völker

---

*„Our global presence and innovative solutions showcase our dedication to excellence and customer satisfaction. At MAX-truder, we build the future with German quality and reliability.“*

# WE BRING OVER 70 YEARS OF EXPERIENCE, EXPERTISE AND TRADITION TO EVERY PROJECT.

# WE USE OUR EXPERIENCE

## 50's The early days



- 1954 / Foundation of weiler Brauer KG
- 1955 / First slipformer for prestressed floor beams
- 1955 / Start of production of a simple concrete saw and prestressing equipment
- 1958 / First participation in the BAUMA exhibition in Munich

## 60's Development

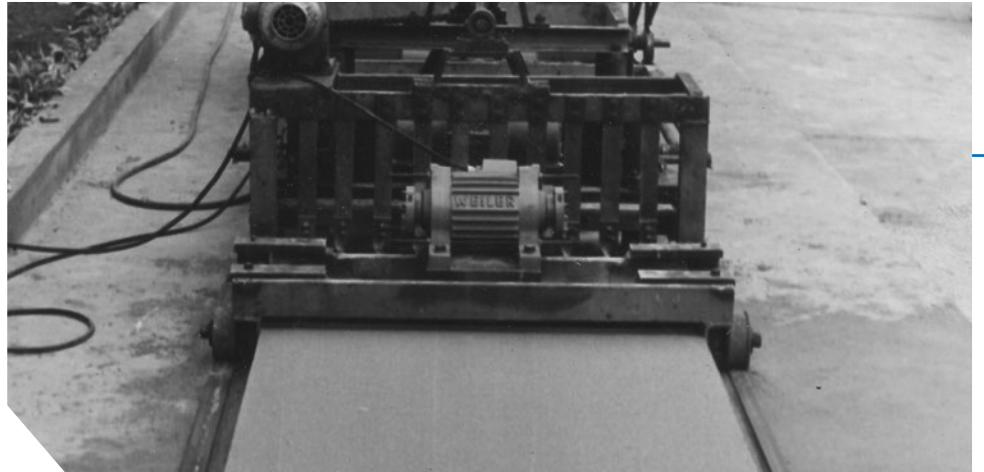

- 1961 / First slipformer for prestressed hollowcore floor slabs
- 1963 / Multilayer slipformer for hollowcore slabs
- 1968 / Delivery of the 10th slipformer plant for T-Beams to Italy

It all began more than 70 years ago, in 1954, when our company was founded in Weiler, a town in Germany, originally under the name weiler Brauer KG. Our early focus was on manufacturing slipformers for the production of prestressed concrete beams.

## MAXHISTORY

The 1960s marked a pivotal time for us as we pioneered advancements in concrete technology. During this decade, we introduced the first slipformer for prestressed hollowcore floor slabs and developed the innovative multilayer slipformer.

## 70's Steps into the world



**1970** / Export expansion: Australia, Canada, the Middle East and Southern Europe

**1972** / First universal slipformer, capable of producing beams and hollowcore slabs

**1976** / Multi-wire stressing jack for simultaneous wire stressing

**1978** / First slipformer with an extended working width of 240 cm

## 80's New focus



**1980** / First fully automatic concrete saw

**1982** / Stationary saw plant for angle and rib cuts

**1986** / BAUMA showcase: universal slipformer with hydraulic four-wheel drive

**1988** / Transition from machine manufacturer to plant manufacturer

The 1980s brought a wave of transformation as we embarked on a journey of innovation and change that reshaped our identity.

# TO DRIVE INNOVATION.

## 90's Automation

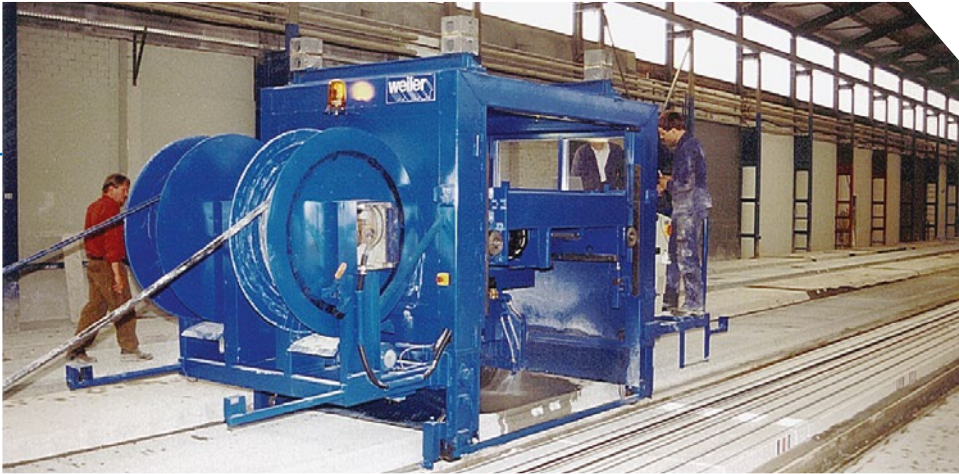

- 1990 / First mobile hydraulic saw for angle and rib cuts
- 1992 / First complete slipformer plant in Turkey, followed by eight more plants
- 1994 / First-generation extruder for hollowcore floor slabs in 15, 20, 25 and 32 cm heights
- 1998 / Second-generation extruder for 40 cm high slabs

The 1990s carried this momentum forward with groundbreaking innovations and significant expansion, pushing the boundaries of what was possible. The 2000s marked an era of extraordinary growth and transformation, as we solidified our position as a leading provider of complete and turnkey precast concrete solutions.

## 00's Advanced technology



- 2000 / First plant installed in South Africa, followed by five more projects
- 2001 / First extruder plant in Bahrain, followed by 22 more plants in the Middle East
- 2004 / First concrete batching plant
- 2009 / Third-generation extruder

# GROUNDBREAKING INNOVATIONS

## 10's Export champion



- 2010 / First mobile precast plant
- 2012 / First tilting table line and first battery mould developed and put into operation
- 2014 / Plant installations in Mongolia, Uzbekistan, Mexico, Russia and Kazakhstan
- 2017 / Acquisition of weiler GmbH and rebranding to MAX-truder GmbH
- 2017 / New hollowcore slab cross sections
- 2019 / First maxtension smart stressing unit

- 2021 / First modular concrete saw
- 2022 / Opening of the largest precast factory in the company's history in Kazakhstan
- 2023 / First wetcast bed production for foundation piles developed and put into operation
- 2024 / First modular angle-cut concrete saw
- 2025 / First preparation machine with an ergonomic operating concept

## 20's Time for innovation



The 2010s continued our legacy of innovation and expansion, earning us international recognition. As we progress through the 2020s, we continue to innovate, redefining the possibilities in the world of precast concrete. Our journey, rooted in a tradition of excellence, continues to shape the future of the industry.

Discover our remarkable journey – from 1954 to today



# WE PROVIDE CUSTOMISED, MODULAR SOLUTIONS

Our innovative solutions and extensive product portfolio meet the diverse needs of global markets. Recognising the unique requirements of each region, we design scalable and modular precast plants to produce a wide range of prestressed and reinforced concrete products.

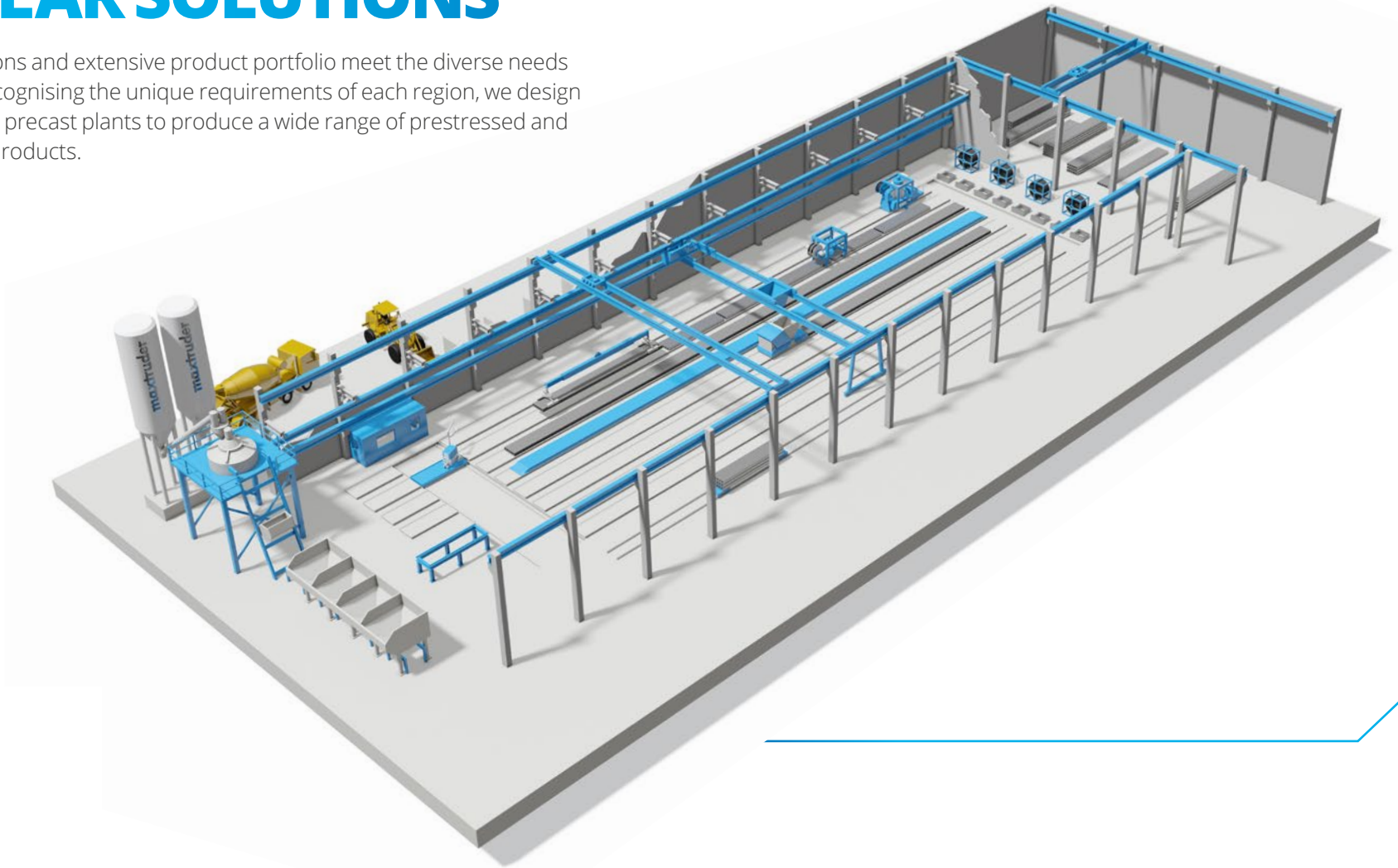

## MAXELEMENTS



Hollowcore slabs



Solid slabs



T-Beams

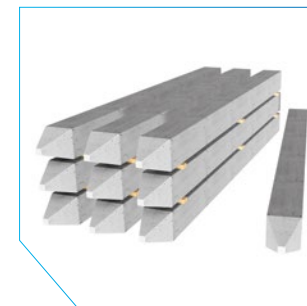

Foundation piles

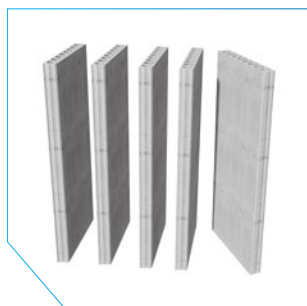

Hollowcore walls

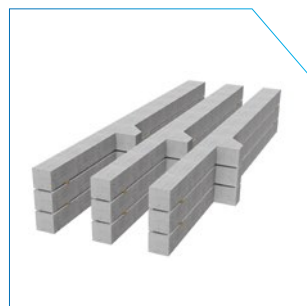

Columns

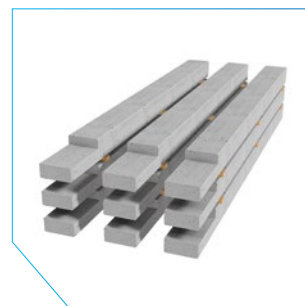

Beams

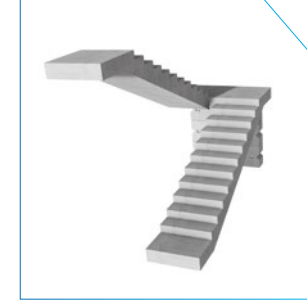

Stairs

**FOR THE PRODUCTION OF  
PRECAST CONCRETE ELEMENTS.**

# WE DEVELOP, DESIGN AND MANUFACTURE IN GERMANY.

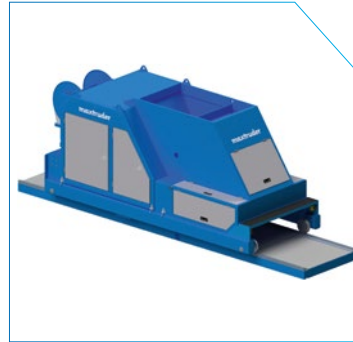

Extruder technology  
maxtruder

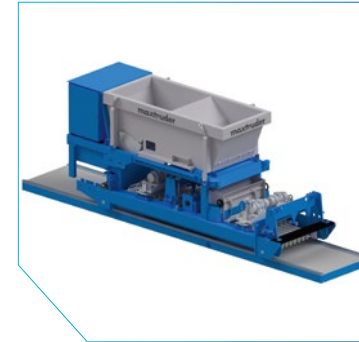

Slipformer technology  
maxcaster

Our machinery is engineered for durability, offering a long lifespan and minimal maintenance requirements to withstand even the harshest conditions. Its modular design ensures flexibility, allowing seamless adaptation to different production needs while maximising efficiency. With a strong focus on reliability and performance, our equipment minimises downtime, lowers operating costs and provides reliable solutions for precast concrete production. Built to last, our robust machines significantly reduce the need for frequent repairs and replacements. Strict quality control measures and high quality standards ensure consistent performance and reliability throughout the entire manufacturing process.

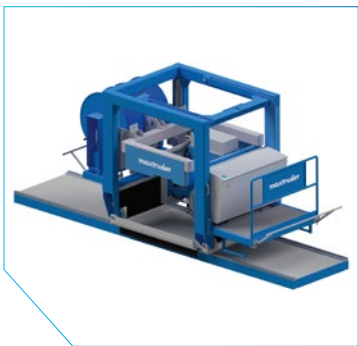

Cutting technology  
maxcut angle



Cutting technology  
maxcut tsf

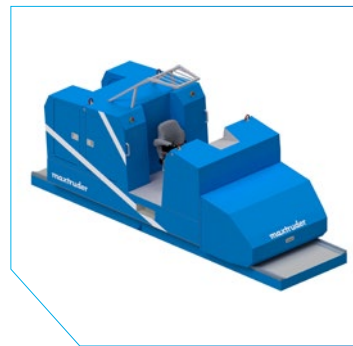

Preparation technology  
maxclean 3:1



Preparation technology  
maxclean 4:1



Prestressing technology  
maxtension smart

# MAXMACHINES



Concrete batching plant



Concrete distribution system



Concrete transport bucket



Crane



Production beds



Stress stands



Foil device



Plotter



Stressing wire reel



Heating system



Lifting equipment



Transport system



Service platform

# WE SUPPORT YOU AT EVERY STEP OF THE WAY.

1

## Your request for a precast plant or living space

We are here to understand your needs and offer you tailored solutions.



2

## Consulting and preplanning

Our experienced specialists support you in planning and designing your projects from the very beginning.

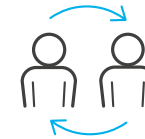

5

## Detailed planning and construction

Our engineering team develops detailed plans and ensures the smooth implementation of your project.



6

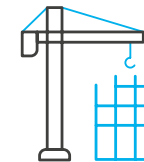

## Delivery of engineering services

We provide comprehensive engineering services to ensure that your precast plant meets the highest standards.



## Delivery of the equipment

We ensure the timely delivery of all necessary equipment for your precast concrete plant.

We offer a comprehensive end-to-end package, from concept development to successful commissioning. We provide our customers with seamless and all-encompassing support for their projects.

With decades of experience and a commitment to excellence, we are your reliable partner for the realisation of precast concrete solutions that meet the highest quality standards.

3

**Support for financing / Profitability analysis**

We support you in analysing the economic viability of your projects and exploring financing options.

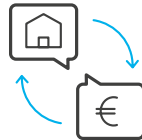

4

**Contract agreement**

We support you throughout the contract process to ensure that all details are clear and transparent.



7

**Commissioning and handover of the precast plant**

We ensure the smooth commissioning of your precast plant.



# WE OPERATE WORLDWIDE, HAVING SUCCESSFULLY

Australia, Austria, **Bahrain**, Belgium, Bosnia and Herzegovina, Botswana, Brazil, Canada, Colombia, **Costa Rica**, Czech Republic, **Croatia**, Denmark, Estonia, Finland, France, **Germany**, **Great Britain**,



Great Britain



Germany



Croatia



Costa Rica



Bahrain



Australia



Kazakhstan



Hungary



Kuwait



Iraq



Lithuania



Ivory Coast

**COMPLETED > 450 PROJECTS  
ACROSS THE GLOBE.**

Hungary, India, Iran, Iraq, Ireland, Italy, Ivory Coast, Kazakhstan,  
Kuwait, Latvia, Lebanon, Libya, Lithuania,



Mexico



Morocco



Mongolia



Qatar



Poland

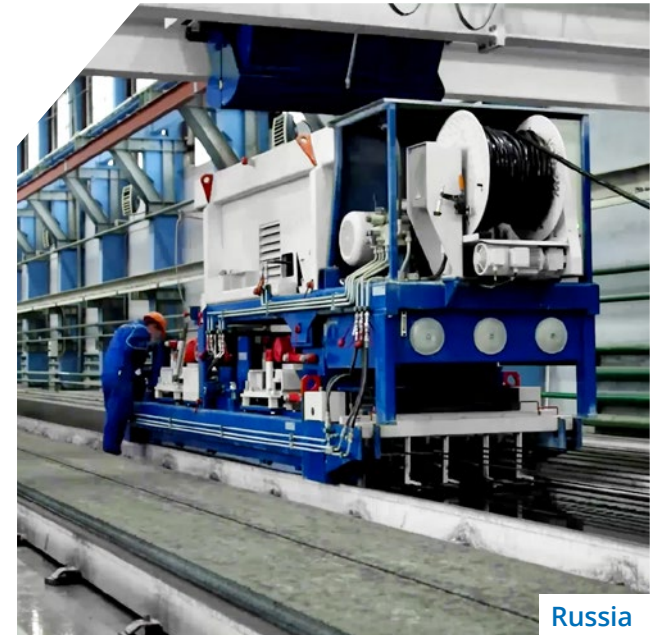

Russia

**WE SET THE STANDARD  
FOR GLOBAL TRUST**

Malta, **Mexico**, **Mongolia**, **Morocco**, Netherlands, Northern Ireland,  
Pakistan, Philippines, **Poland**, Portugal, **Qatar**, Romania, **Russia**,

# WITH GERMAN PRECISION AND QUALITY.

Saudi Arabia, Scotland, South Africa, Sri Lanka, Switzerland, Syria, Thailand, Tunisia, Türkiye, Ukraine, United Arab Emirates, United States of America, Uzbekistan, Vietnam.



Türkiye



Uzbekistan



Syria



Saudi Arabia



South Africa



Ukraine

# CONSTRUCTION OF AFFORDABLE, BRIGHT AND COMFORTABLE APARTMENTS

for the residents of Astana — learn more about this project.

With an area of 15,000 square meters, SG Beton is the largest precast concrete factory in Kazakhstan. The factory was built as part of a project by the construction company G-PARK LLP in order to produce its own building materials to create more affordable and attractive housing in Astana. MAX-truder played a key role in this project by providing engineering, design, consulting and technology for the factory's construction. G-PARK's goal was to significantly reduce the import of materials for production. Since 2014, G-PARK has provided over one million square meters of living space for approximately 60,000 residents of Astana.



Gabit Satmagambetov  
General Director of the  
G-Park construction  
company group

*„Currently, we have the opportunity to provide the residents of Astana with high-quality and affordable housing while making a positive contribution to the local job market. Our partnership with MAX-truder has played a key role in our success.“*



Amangeldy Kakibayev  
Plant Director of  
SG Beton LLP

*„Working with MAX-truder has significantly transformed our operations at SG Beton. Their advanced production technology has not only helped us reduce material costs by 70% but also increased our production capacity and efficiency.“*

Previously, G-PARK relied on imported materials from Uzbekistan, Ukraine and Russia, which negatively impacted the cost of the final product. In order to reduce costs, G-PARK decided to gradually transition to in-house production starting in 2021. This initiative also includes the construction of a brick factory, which is now the largest in Central Asia with a production capacity of over 120 million units per year. The SG Beton factory started production in 2022 and is currently the most modern in terms of production technology.

## MAX-TRUDER INSIDE – INTRODUCING SG BETON

The factory consists of 14 lines: 6 lines for 1.5m hollowcore slabs and 8 lines for 1.2m hollowcore slabs. In-house production allows the company to meet its own production needs while also selling products on the market. Using MAX-truder production technology and machinery, the factory produces prestressed hollowcore slabs with an annual capacity of 650,000 m<sup>2</sup> and foundation piles with an annual output of 450,000 linear meters.

Fully automated systems minimise human error and ensure fast, smooth production processes. The use of the latest technologies enables high productivity while ensuring efficient use of raw materials and water. The factory employs 240 people and produces a wide range of materials, including hollowcore floor slabs, foundation piles, beams, foundation blocks and stairs. The establishment of local building material plants reduces import dependency – allowing G-PARK to save around 70 percent on import costs – and helps stabilise housing prices, supporting its goal of providing affordable, bright and comfortable housing in Astana.



Covering 15,000 square meters, SG Beton is the largest precast concrete factory in Kazakhstan



Employees of the SG Beton factory in Astana



MAX-truder machinery in operation

**650,000 m<sup>2</sup>**

Annual production capacity of prestressed hollowcore slabs

**450,000 m**

Annual production capacity of foundation piles

**1,000,000 m<sup>2</sup>**

of living space for approx. 60,000 residents of Astana

*SG Beton precast factory*



## PRECAST YOUR FUTURE.

Exciting news from the industry:  
Discover our social media channels!

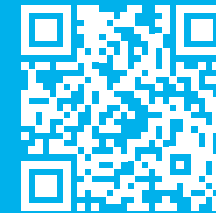

Head office  
MAX-truder GmbH  
Sudenburger Wuhne 60  
39116 Magdeburg, Germany

Branch office  
MAX-truder GmbH  
Rheinstraße 40  
55435 Gau-Algesheim, Germany



+49 (0) 6725 300 990



info@maxtruder.com



www.maxtruder.com

EN

Designed  
developed and  
made in Germany

